

Balustrade Systems

Step 1: Using Existing or Alternate Attachment Supports for your Railing System

- 1.1 If existing or alternate supports, newel posts, porch posts, etc. will be used for attaching a Chemcrest railing system, please install them according to the manufacturer's specifications, and skip to **Step 3**.

Step 2: Positioning Chemcrest Newel Posts

- 2.1 Temporarily place the Newel Posts in the proper locations on your substrate, or measure the O/S dimensions of your posts.
- 2.2 Draw (or trace) these measurements in the proper locations on your substrate. Make sure these markings are straight and square.
- 2.3 Carefully and accurately, measure the distance(s) between each newel post(s). These measurements will be used to cut your rails to the appropriate lengths.
- 2.4 Remove the newel posts revealing the markings on your substrate.
- 2.5 Determine the center point of each newel post on your substrate by drawing intersecting diagonal lines from each corner of your marked newel post locations.
- 2.6 Concrete Substrate: If your substrate is not concrete, skip to **2.7**.
 - 2.6.1 Drill a 7/8" diameter hole 2 1/4" deep at this center point.
 - 2.6.2 Using a hammer, insert the concrete anchor and tap flush with the substrate surface.
 - 2.6.3 Continue with **Step 3**.
- 2.7 Wood and Composite Substrate:
 - 2.7.1 Locate the round anchor plate with a center-mounted nut.
 - 2.7.2 Center this plate on your centerline newel post markings and mark the location of the four bolt holes.
 - 2.7.3 Remove the plate and drill four small 3/16" pilot holes at these locations.
 - 2.7.4 Replace the round metal anchor plate and bolt it to the substrate using four (4) 5/16" x 3" lag bolts.

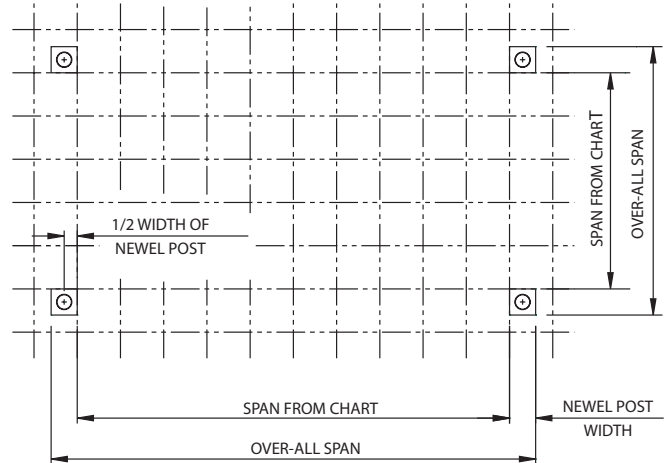

Step 3: Securing Angle Brackets to Supporting Posts

- 3.1 Determine the placement of your top and bottom rails. You will need:
 - 3.1.1 Height of Baluster (not including pipe)
 - 3.1.2 Height of Bottom Rail
 - 3.1.3 Distance between bottom rail and substrate
 - 3.1.4 Four (4) Aluminum L-brackets
 - 3.1.5 Eight (8) 1/4" Hex Head bolts
 - 3.1.6 Eight (8) 1/4" Lock washers
 - 3.1.7 Eight (8) 1/4" Hex Head nuts
- 3.2 The position of the top L-bracket will be at the height of the sum of the three measurements above (**3.1.1 + 3.1.2 + 3.1.3**).
- 3.3 The top of the lower L-bracket should be positioned below the bottom rail that you measured in **3.1.2**.
- 3.4 Center and mark the position of the aluminum L-brackets (**3.1.4**) on the face of the newel (or other support) post (Normal fastening methods mount the L-brackets to the underside of the rails).
- 3.5 Mark the hole locations of the brackets (use the non-tapered holes) on the face of the newel (or other support) post.
- 3.6 Remove the brackets and drill four (4) 1/4" holes into the newel post and through the internal pipe (other support structures may require alternate attachment hardware and fastening techniques).
- 3.7 Secure the brackets to the Chemcrest newel posts using the 1/4" bolts (**3.1.5**), washers (**3.1.6**) and nuts (**3.1.7**).

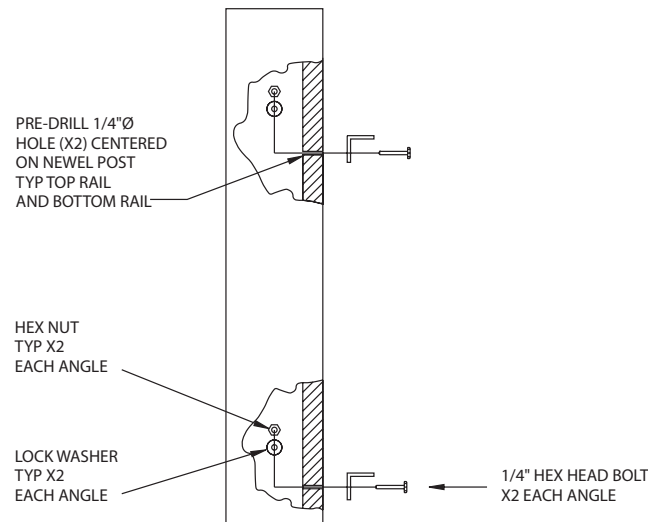

Balustrade Systems

Step 4: Preparing the Rails

- 4.1 Lay out your rails and determine how they will be assembled with the proper surfaces facing up and down according to the Chemcrest product drawings.
- 4.2 Determine how many balusters will be required for each span by dividing the total rail length by the "On-Center" (O/C) spacing measurement found in the catalog for each baluster. Round UP if your measurement is not an even number. The O/C measurement is the MAXIMUM distance between the center-point of each baluster that guarantees that your finished railing will comply with the national 4" ball rule.
- 4.3 If you DID NOT have to round up, skip to **Step 5**.
- 4.4 If you DID round up, you have to re-calculate your O/C measurement. Take the total length of your span and divide it by the number of balusters that you calculated (after you rounded up). This is the O/C spacing that you will use for each baluster placement.

Step 5: Pre-drilling and Baluster Placement

- 5.1 Where do you drill the first baluster hole? Use the O/C measurement you calculated from **Step 4**, and divide it in half. Use this measurement as your starting point from the end of the rail (it should calculate to be the same as the space left after your last baluster at the opposite end of the rail).
- 5.2 Using a pencil, mark these spacing points along the UNDERSIDE of the top rail and the TOP of the bottom rail along the centerline. Be VERY CAREFUL to mark exactly the same locations on both rails so that the balusters sit perfectly vertical after assembly. Double-check your measurements and baluster quantities.
- 5.3 Check the Chemcrest product drawings to determine the diameter of the pipe extending from each end of the baluster. Bore out a hole of the corresponding diameter to a depth of 1 1/2" also penetrating the internal pipe inside the rails.
- 5.4 Remove any excess product from the holes.

Step 6: Attaching the Balusters to the Rails

- 6.1 Use Chemcrest's polyurethane based adhesive AT101-300 (p 122), PL-Premium or approved equal (and optional mechanical fasteners) for this assembly process.
- 6.2 Check the length of all of the balusters. Some sanding or trimming may be required in order to make sure the balusters are all consistent.
- 6.3 Apply a generous bead of adhesive to all contact surfaces such that it will spread across the entire contact surface.
- 6.4 Place these balusters into your pre-drilled holes on the bottom rail first and ensure that they are turned straight and aligned.
- 6.5 Line up the balusters to your pre-drilled holes in your top rail and drop it in place. Use a rubber mallet to tap the top rail down ensuring a tight fit. "Toe-nail" the balusters in place to prevent the balusters from turning while the adhesive sets up.
- 6.6 Use multiple cargo or ratchet straps to clamp the railing system together during this adhesive drying time.
- 6.7 Follow the adhesive manufacturers recommended curing time and clean up procedures. Remove excess adhesive as soon as possible (before it has set up). This will make the finishing process much easier.
- 6.8 After the adhesive has set up, sand and patch any irregularities using an exterior, non-shrinking spackle, Bondo or equivalent wood filler.

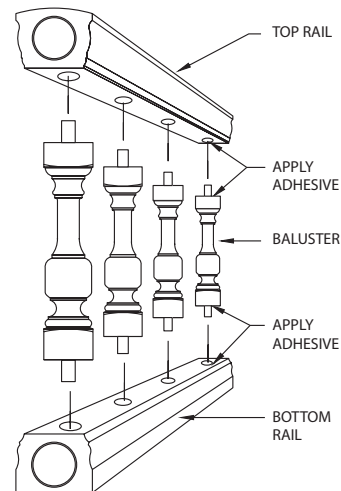

Note: This diagram is showing only a segment of railing and is for display purposes only.

Balustrade Systems

Step 7: Attach railing sections to the Newel Posts

- 7.1 Attach the top and bottom rails to the newel post brackets that you installed in **Step 3** using the screws provided with your rail hardware kit.

Step 8: Secure completed railing system onto substrate

- 8.1 Set your railing system into place over the previously marked newel post locations and mounting hardware from **Step 2**.
- 8.2 Insert the 1/2" threaded rod through the center of the newel posts and into the substrate anchors that were installed in **Step 2**. Thread the rod firmly into these substrate anchors.
- 8.3 Slide the top Tie Down bracket over the threaded rod and position the bracket into the pre-cut newel post grooves so that the top of the bracket is flush with the top of the newel post.
- 8.4 Secure this attachment with the 1/2" lock washer and nut. Using a hacksaw, mark and remove any excess threaded rod that may extend past the top of the newel post.

Step 9: Support Blocks

- 9.1 In order to ensure the stability and integrity of the balustrade system, support blocks should be placed under the bottom rail for any span that exceeds 48". Anchor these support blocks using adhesive on all contact surfaces and "Toe-Nail" screws.

Step 10: Decorative Balls and Caps

- 10.1 Locate and test-fit the caps and/or ball tops that you have chosen to complete the top of your newel posts.
- 10.2 Apply adhesive to all contact surfaces between the newel post and cap/ball top.
- 10.3 Center the cap on the post, and use screws to secure the cap until the adhesive has cured.
- 10.4 Patch, sand and prime all areas of your balustrade system where installation marks or holes have been made.

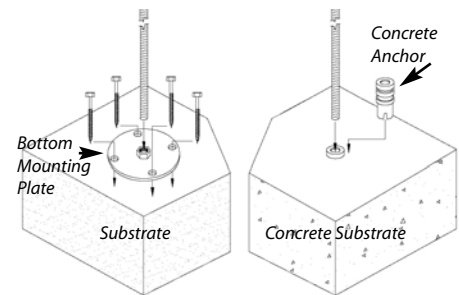
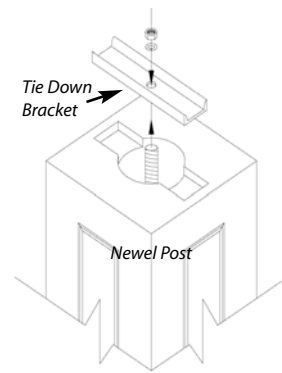
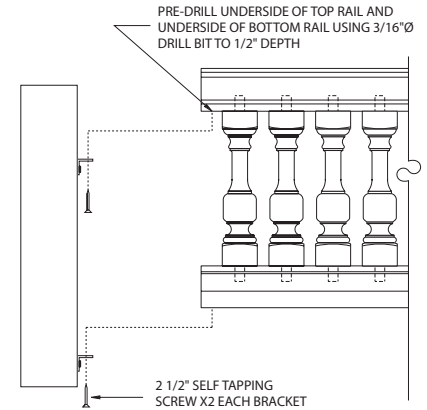

Your balustrade system is now ready for finishing. All Chemcrest products are supplied with a white double primed coating, ready for customer applied finish topcoat. High quality latex or oil based paints should be used.

Balustrade Systems

Span Chart for Newel Posts

- 1 Reference the span for each baluster system you are doing. This is the total opening to fill with guard rail. DO NOT combine separate spans.
- 2 If your rail is 10 feet use the column marked (10'). If your rail is 12 feet, use the column marked (12').
- 3 The first number indicates the suggested number of newel posts to use. The second number indicates the space between each newel post.

Spans	BP4706		BP4806		BP4807		BP4808/-P/-P-C		BP4812		BP4414/-P/-P-C	
	10' rail	12' rail	10' rail	12' rail	10' rail	12' rail	10' rail	12' rail	10' rail	12' rail	10' rail	12' rail
10'	2-108"	2-108"	2-108"	2-108"	2-105"	2-105"	2-104"	2-104"	2-96"	2-96"	2-92"*	2-92"
11'	2-120"	2-120"	2-120"	2-120"	2-117"	2-117"	2-116"	2-116"	2-108"	2-108"	2-104"	2-104"
12'	3-63"	2-132"	3-63"	2-132"	3-61"	2-129"	3-60"	2-128"	2-120"	2-120"	2-116"	2-116"
13'	3-69"	2-144"	3-69"	2-144"	3-67"	2-141"	3-66"	2-140"	3-60"*	2-132"	3-57"*	2-128"
14'	3-75"	3-75"	3-75"	3-75"	3-73"	3-73"	3-72"	3-72"	3-66"*	2-144"	3-63"*	2-140"
15'	3-81"	3-81"	3-81"	3-81"	3-79"	3-79"	3-78"	3-78"	3-72"*	3-72"	3-69"*	3-69"
16'	3-87"	3-87"	3-87"	3-87"	3-85"	3-85"	3-84"	3-84"	3-78"*	3-78"	3-75"*	3-75"
17'	3-93"	3-93"	3-93"	3-93"	3-91"	3-91"	3-90"	3-90"	3-84"*	3-84"	3-81"*	3-81"
18'	3-99"	3-99"	3-99"	3-99"	3-97"	3-97"	3-96"	3-96"	3-90"*	3-90"	3-87"*	3-87"
19'	3-105"	3-105"	3-105"	3-105"	3-103"	3-103"	3-102"	3-102"	3-96"*	3-96"	3-93"*	3-93"
20'	3-111"	3-111"	3-111"	3-111"	3-109"	3-109"	3-108"	3-108"	3-102"	3-102"	3-99"	3-99"
21'	3-117"	3-117"	3-117"	3-117"	3-115"	3-115"	3-114"	3-114"	3-108"	3-108"	3-105"	3-105"
22'	4-80"	3-123"	4-80"	3-123"	4-78"	3-121"	3-120"	3-120"	3-114"	3-114"	3-111"	3-111"
23'	4-84"	3-129"	4-84"	3-129"	4-82"	3-127"	4-82"	3-126"	3-120"	3-120"	3-117"	3-117"
24'	4-88"	3-135"	4-88"	3-135"	4-86"	3-133"	4-86"	3-132"	4-80"*	3-126"	4-78"*	3-123"
25'	4-92"	3-144"	4-92"	3-144"	4-90"	3-139"	4-90"	3-138"	4-84"*	3-132"	4-82"*	3-129"
26'	4-96"	4-96"	4-96"	4-96"	4-94"	4-94"	4-94"	3-144"	4-88"*	3-138"	4-86"*	3-135"
27'	4-100"	4-100"	4-100"	4-100"	4-98"	4-98"	4-98"	4-98"	4-92"*	3-144"	4-90"*	3-141"
28'	4-104"	4-104"	4-104"	4-104"	4-102"	4-102"	4-102"	4-102"	4-96"*	4-96"	4-94"*	4-94"
29'	4-108"	4-108"	4-108"	4-108"	4-106"	4-106"	4-106"	4-106"	4-100"	4-100"	4-98"	4-98"
30'	4-112"	4-112"	4-112"	4-112"	4-110"	4-110"	4-110"	4-110"	4-104"	4-104"	4-102"	4-102"
31'	4-116"	4-116"	4-116"	4-116"	4-114"	4-114"	4-114"	4-114"	4-108"	4-108"	4-106"	4-106"
32'	4-120"	4-120"	4-120"	4-120"	4-118"	4-118"	4-118"	4-118"	4-112"	4-112"	4-110"	4-110"
33'	5-91.5"	4-124"	5-91.5"	4-124"	5-90"	4-122"	5-89"	4-122"	4-116"	4-116"	4-114"	4-114"
34'	5-94.5"	4-128"	5-94.5"	4-128"	5-93"	4-126"	5-92"	4-126"	4-120"	4-120"	4-118"	4-118"
35'	5-97.5"	4-132"	5-97.5"	4-132"	5-96"	4-130"	5-95"	4-130"	5-90"*	4-124"	5-88"*	4-122"
36'	5-100.5"	4-136"	5-100.5"	4-136"	5-99"	4-134"	5-98"	4-134"	5-93"*	4-128"	5-91"*	4-126"
37'	5-103.5"	4-140"	5-103.5"	4-140"	5-102"	4-138"	5-101"	4-138"	5-96"*	4-132"	5-94"*	4-130"
38'	5-106.5"	4-144"	5-106.5"	4-144"	5-105"	4-142"	5-104"	4-142"	5-99"	4-136"	5-97"	4-134"
39'	5-110"	5-110"	5-110"	5-110"	5-108"	5-108"	5-107"	5-107"	5-102"	4-140"	5-100"	4-138"
40'	5-113"	5-113"	5-113"	5-113"	5-111"	5-111"	5-110"	5-110"	5-105"	4-144"	5-103"	4-142"
41'	5-116"	5-116"	5-116"	5-116"	5-114"	5-114"	5-113"	5-113"	5-108"	5-108"	5-106"	5-106"
42'	5-119"	5-119"	5-119"	5-119"	5-117"	5-117"	5-116"	5-116"	5-111"	5-111"	5-109"	5-109"
43'	6-96"	5-122"	6-96"	5-122"	5-120"	5-120"	5-119"	5-119"	5-114"	5-114"	5-112"	5-112"
44'	6-98"	5-125"	6-98"	5-125"	6-97"	5-123"	6-96"	5-121"	5-117"	5-117"	5-115"	5-115"
45'	6-101"	5-128"	6-101"	5-128"	6-99"	5-126"	6-98"	5-124"	5-120"	5-120"	5-118"	5-118"
46'	6-104"	5-131"	6-104"	5-131"	6-102"	5-129"	6-101"	5-127"	6-96"*	5-123"	6-94"*	5-121"
47'	6-106"	5-134"	6-106"	5-134"	6-104"	5-132"	6-103"	5-130"	6-99"	5-126"	6-96"*	5-124"
48'	6-108"	5-137"	6-108"	5-137"	6-106"	5-135"	6-106"	5-133"	6-101"	5-129"	6-99"	5-127"
49'	6-110"	5-140"	6-110"	5-140"	6-108"	5-138"	6-108"	5-136"	6-104"	5-132"	6-101"	5-130"

* If you have chosen BR7100-10 or BR7110-10 and your reference includes an asterisk (*), order BR7100-08 and BR7110-08 respectively.

The information and calculations provided here by Chemcrest are guidelines only. It is entirely the responsibility of the specifier and installer to ensure that the building codes and structural integrity is met by the specific balustrade assembly.

Balustrade Systems

Baluster Span Chart

1 The number indicated is the suggested number of balusters to use in equal divisions between the posts.

Spans	24	30	36	42	48	54	60	66	72	78	84	90	96	102	108	114	120	126	132	138	144
B7016	4	5	6	7	8	9	10	11	12	13	14	15	16	16	17	18	19	20	21	22	23
B7019	3	4	5	6	7	8	9	10	10	11	12	13	14	15	16	17	17	18	19	20	21
B7020*	x	x	x	x	x	x	x	x	x	x	x	x	x	x	x	x	x	x	x	x	x
B7022	3	4	5	6	7	8	9	10	11	11	12	13	14	15	16	17	18	19	19	20	21
B7023*	x	x	x	x	x	x	x	x	x	x	x	x	x	x	x	x	x	x	x	x	x
B7024	3	4	4	5	6	6	7	8	8	9	10	11	11	12	13	13	14	15	16	16	17
B7025	3	4	5	6	6	7	8	9	10	10	11	12	13	14	14	15	16	17	18	18	19
B7026	3	4	4	5	6	7	7	8	9	10	10	11	12	13	13	14	15	16	16	17	18
B7027	4	5	6	7	8	9	10	11	12	13	14	15	15	17	18	19	20	21	22	23	24
B7028	4	5	6	7	8	10	11	12	13	14	15	16	17	18	19	20	21	22	23	24	25
B7030	3	4	5	6	7	8	9	10	10	11	12	13	14	15	16	17	17	18	19	20	21
B7030-6	3	4	5	6	7	8	9	10	10	11	12	13	14	15	16	17	17	18	19	20	21
B7031	3	4	5	6	7	8	8	9	10	11	12	13	14	14	15	16	17	18	19	20	20
B7032	3	3	4	5	5	6	6	7	8	8	9	10	10	11	12	12	13	14	14	15	15
B7035	4	5	5	6	7	8	9	10	11	12	13	13	14	15	16	17	18	19	20	21	21
B7036	3	3	4	5	5	6	6	7	8	8	9	10	10	11	12	12	13	14	14	15	15
B7037*	x	x	x	x	x	x	x	x	x	x	x	x	x	x	x	x	x	x	x	x	x
B7038	4	5	6	7	8	10	11	12	13	14	15	16	17	18	19	20	21	22	23	24	25
B7040	4	5	6	7	8	9	10	11	12	13	14	15	16	18	19	20	21	22	23	24	25
B7115	4	5	6	7	8	9	10	11	12	12	13	14	15	17	18	19	20	21	22	23	23
B7120	4	5	6	7	8	9	10	11	12	13	14	15	16	17	18	19	20	21	22	23	24
B7122	4	4	5	6	7	8	9	10	11	12	13	13	14	15	16	17	18	19	20	21	22
B7123	3	4	5	6	7	8	8	9	10	11	12	13	14	14	15	16	17	18	19	20	20
B7124	4	5	6	7	8	9	10	11	12	13	14	15	16	17	18	19	20	21	22	23	24
B7124-6	4	5	6	7	8	9	10	11	12	13	14	15	16	17	18	19	20	21	22	23	24
B7127	4	5	6	7	7	8	9	10	11	12	13	14	15	16	17	18	19	20	21	22	23
B7128	4	5	6	7	8	9	10	10	11	12	13	14	15	16	17	18	19	20	21	22	23
B7130	6	7	8	9	10	11	13	14	15	16	18	19	20	22	23	24	26	27	28	30	31
B7131	4	5	6	6	7	8	9	10	11	12	13	14	15	16	17	18	19	20	21	22	22
B7132	3	4	5	x	x	x	8	9	10	11	x	x	13	14	15	16	x	x	18	19	20
B7134	5	7	8	9	10	11	12	14	15	16	17	19	20	22	23	24	25	27	28	29	30
B7135	5	6	7	8	9	10	10	11	12	13	14	15	16	18	19	20	21	22	23	24	25
B7137	4	5	6	7	8	9	10	11	12	13	14	15	16	17	18	19	20	21	22	23	24
B7218	4	5	6	7	8	10	11	12	13	14	15	16	17	18	19	20	21	23	24	25	26
B7220	4	5	6	7	8	10	11	12	13	14	15	16	17	18	19	20	21	23	24	25	26
B7224	4	5	6	7	8	10	11	12	13	14	15	16	17	18	19	20	21	22	23	24	25
B7224-6	4	5	6	7	8	10	11	12	13	14	15	16	17	18	19	20	21	22	23	24	25
B7225	4	4	5	6	7	8	9	10	11	12	13	13	14	15	16	17	18	19	20	21	22
B7225-6	4	4	5	6	7	8	9	10	11	12	13	13	14	15	16	17	18	19	20	21	22
B7228	4	5	6	7	8	9	10	11	12	13	14	15	16	17	18	19	20	21	22	23	24
B7230	4	5	5	6	7	8	9	10	11	12	13	13	14	15	16	17	18	19	20	21	21
B7231	3	4	5	6	7	8	9	9	10	11	12	13	14	15	15	16	17	18	19	20	21
B7232	3	4	5	x	x	x	8	9	10	11	x	x	13	14	15	16	x	x	18	19	20
B7320	4	5	5	6	7	8	9	10	11	12	13	13	14	15	16	17	18	19	20	21	21
B7332	3	4	5	6	7	8	9	10	10	11	12	13	14	15	16	17	17	18	19	20	21
B7420	4	5	6	7	8	9	10	11	12	13	14	15	16	18	19	20	21	22	23	24	25
B7424	4	5	6	7	8	9	10	11	12	13	14	15	16	18	19	20	21	22	23	24	25
B7428	4	5	6	7	8	9	10	11	12	13	14	15	16	18	19	20	21	22	23	24	25
B7430	4	5	6	7	8	9	10	10	11	12	13	14	15	16	17	18	19	20	21	21	22
B7432	4	5	6	7	8	9	10	11	12	13	14	15	16	18	19	20	21	22	23	24	25
B7438	4	5	6	7	8	9	10	11	12	13	14	15	16	18	19	20	21	22	23	24	25
B7448	4	5	6	7	8	9	10	11	12	13	14	15	16	18	19	20	21	22	23	24	25
B7532	4	5	6	7	8	10	11	12	13	14	15	16	17	18	19	20	21	22	23	24	25
B7624	3	4	5	6	7	8	8	9	10	11	12	13	14	14	15	16	17	18	19	20	20
B7728	3	x	x	5	6	7	8	x	9	10	11	12	12	13	14	15	x	16	17	18	19
B7728-2T	3	x	x	5	6	7	8	x	9	10	11	12	12	13	14	15	x	16	17	18	19

Balusters are listed in keeping with the "4-inch ball rule" as specified by National Building Codes. On center spacing may be decreased based on number of parts specified in chart. All balusters specified in chart will fit in equal divisions within spans listed. If the span recommended in the "Span Chart for Newel Posts" falls between the spans listed in the chart above, always use the next greatest span.

* For cosmetic purposes only. This baluster does not comply with the 4-inch ball rule.

